

Quality Assurance Programme for the Environmental Testing of CMS Tracker Optical Links

K. Gill, R. Grabit, J. Troska, F. Vasey and A. Zanet

CERN, 1211 Geneva 23, Switzerland
karl.gill@cern.ch

Abstract

The QA programme is reviewed for the environmental compliance tests of commercial off-the-shelf (COTS) components for the CMS Tracker Optical link system. These environmental tests will take place in the pre-production and final production phases of the project and will measure radiation resistance, component lifetime, and sensitivity to magnetic fields. The evolution of the programme from small-scale prototype tests to the final pre-production manufacturing tests is outlined and the main environmental effects expected for optical links operating within the Tracker are summarised. A special feature of the environmental QA programme is the plan for Advance Validation Tests (AVT's) developed in close collaboration with the various industrial partners. AVT procedures involve validation of a relatively small set of basic samples in advance of the full production of the corresponding batch of devices. Only those lots that have been confirmed as sufficiently rad-tolerant will be purchased and used in the final production.

I. INTRODUCTION

Final production of the CMS Tracker optical links will begin in 2001 and continue until 2004. Approximately 40000 uni-directional analogue optical links, and ~1000 bi-directional digital optical links will be produced. Quality Assurance (QA) procedures have been developed in order to guarantee that the final links meet the specified performance and are produced on schedule. A detailed QA manual has been written[1] and in this paper we focus on the part of the QA programme concerning environmental testing of components.

The CMS Tracker environment is characterised by the high levels of radiation, up to $\sim 2 \times 10^{14}/\text{cm}^2$ fluence and 100kGy ionising dose for the optical link components over the first 10 years of operation[2]. The particle fluence at the innermost modules of the Tracker is dominated by pions and photons, with energies $\sim 100\text{MeV}$, and by $\sim 1\text{MeV}$ neutrons at the outermost modules. In addition to resisting the radiation environment the components must operate in a 4T magnetic field and at temperatures close to -10°C .

The basic elements of the optical link system are illustrated in Fig. 1[1]. Both analogue and digital optical links for the CMS Tracker share the same basic components, namely 1310nm InGaAsP/InP multi-quantum-well edge-emitting lasers and InGaAs p-i-n photodiodes coupled to single-mode optical fibre. The optical fibre is in the form of buffered single-way fibre, ruggedized 12-way ribbon fibre cable, and dense, ruggedized 96-way multi-ribbon cable. MU-based single-way, and MT-based multi-way, optical connectors are used at the various optical patch panels.

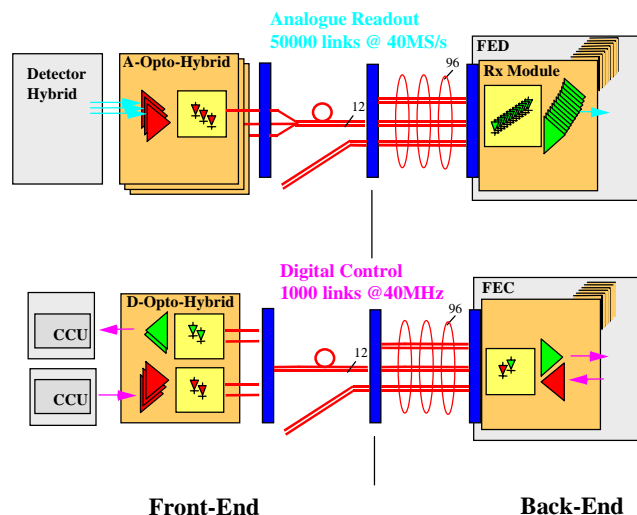

Figure 1: Optical link systems. Components at the front-end are exposed to radiation, a 4T magnetic field, and will operate at -10°C .

All of the elements listed above are either commercial off-the-shelf (COTS) components or devices based on COTS. In an extensive series of sample tests, which was carried out in the development phase of the project, the sensitivity of the various link components to the expected Tracker environment has been thoroughly investigated[3]. These data have allowed identification and selection of suitable components and have also allowed tailoring of the link specifications to compensate for unavoidable effects, e.g. radiation damage, now that the effects have been well quantified.

Despite having restricted the final choice of candidate components to those that have passed the sample tests, the use of COTS means that environmental QA testing must continue into the production phase of the project. This is simply because the radiation resistance of the COTS components can not be guaranteed by the vendors as the devices are not manufacturer-qualified for the CMS Tracker environment.

It is clear that we must avoid, if possible, any situation where a delivered production batch of fully assembled components is found to be non-compliant with the Tracker environment. Diagnosing and remedying such a problem would incur a substantial delay in the already tight production schedule.

We propose a programme of QA procedures, outlined in the following section, that will guarantee that the final optical links will meet the specified functional performance and environmental resistance, whilst also avoiding the possibility of rejecting fully assembled devices due to non-compliance with the Tracker environment. A particular requirement of the programme is that we must validate laser diodes, fibre and

photodiodes in special 'Advance Validation Tests' (AVT's). The AVT procedures are described in detail in this paper, and for details of other QA issues and requirements the reader is referred to the full QA manual[1].

II. QA PROCEDURES

From the development of the first prototypes to large-scale production, a wide range of QA procedures has been, and will be, implemented as shown in Fig. 2[1].

Following extensive testing of early prototypes[3], the first formal step in the QA procedure was the technical qualification of suppliers in the framework of CERN market surveys. Market surveys for semiconductor lasers (MS2690) and optical connectors (MS2691) were issued in 1999. Market surveys for optical fibre, ribbon and cable (MS2811) as well as for receiver modules (MS2810) were issued in 2000. In all of these surveys, evaluation samples were requested from the companies interested in tendering, and subjected to a sample validation procedure described in the next section. Based on the results of this sample-validation procedure, manufacturers were qualified and those that were successful were invited to tender for the production of final components or assemblies.

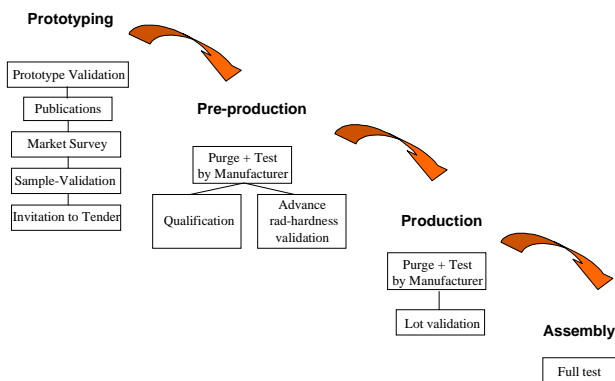

Figure 2: QA procedures during various project phases.

A. Sample validation

Evaluation samples sent to CERN in the framework of market surveys were validated according to the procedure sketched in Fig. 3. In the semiconductor laser case (MS2690), the irradiation consisted of both gamma and neutron tests, while in the connector (MS2691) and fibre/cable (MS2811) cases it consisted only of gamma tests. These choices of radiation sources reflected the types of effects, that were observed in the earlier tests[3]. No CERN-specific environmental tests (B-field or Irradiation) were performed on the Rx modules (MS2810), which will be operated in the counting room, away from the radiation and magnetic field. Results of Sample-Validation tests made within the Market Surveys were published in confidential reports, with a copy sent to the manufacturer.

Thorough environmental tests have also been made within the CERN EP/MIC group on samples of the electronic chips, namely the laser driver[4] and digital receiver chip[5], that will be used in the optical links and located within the Tracker.

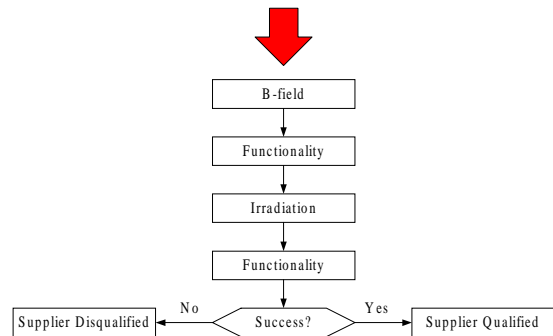

Figure 3: Sample validation procedures.

B. Pre-production qualification

Qualification of the pre-production will involve rigorous testing of fully-assembled devices sampled from the pre-production delivery in order to qualify the devices and manufacturing processes in preparation for full production. This includes evaluating the compliance of the components and assemblies to their specifications whilst, or following, exposure to conditions representative of the Tracker environment, as illustrated in Fig. 4. Results of pre-production qualification tests will be archived in the EDMS database, with a copy sent to the manufacturer.

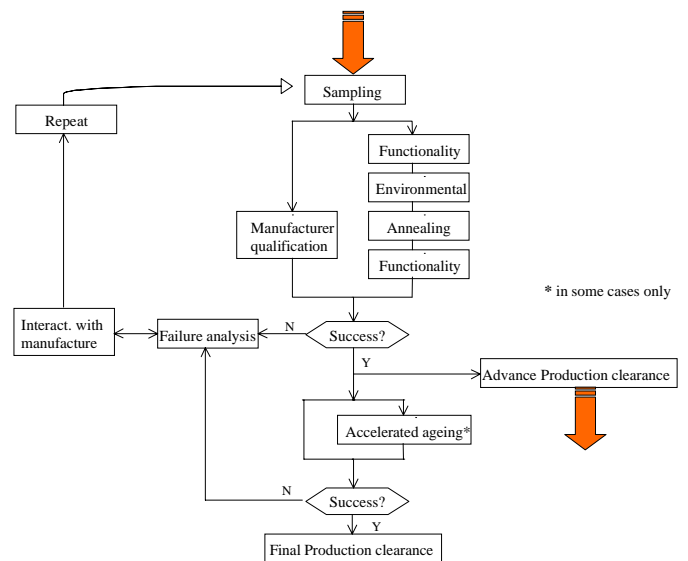

Figure 4: Flow chart of the pre-production qualification procedure.

C. Advance Validation Test (AVT)

The primary aim of the AVT procedure is to avoid the problems of the possible rejection of whole batches of assembled devices because of non-compliance with the Tracker environment. This would clearly benefit both the component suppliers and the CMS groups responsible for the optical links.

The AVT procedures will be applied to the lasers, photodiodes and optical fibre. These elements of the optical links are recognised as being the most sensitive to the Tracker environment, particularly the strong radiation field.

The advance validation procedure is outlined in Fig. 5. Where AVT overlaps with pre-production qualification of the same components, it should be possible to streamline significantly the pre-production qualification procedure. As with the other QA tests, results will be archived in the EDMS database, and a copy sent to the manufacturer.

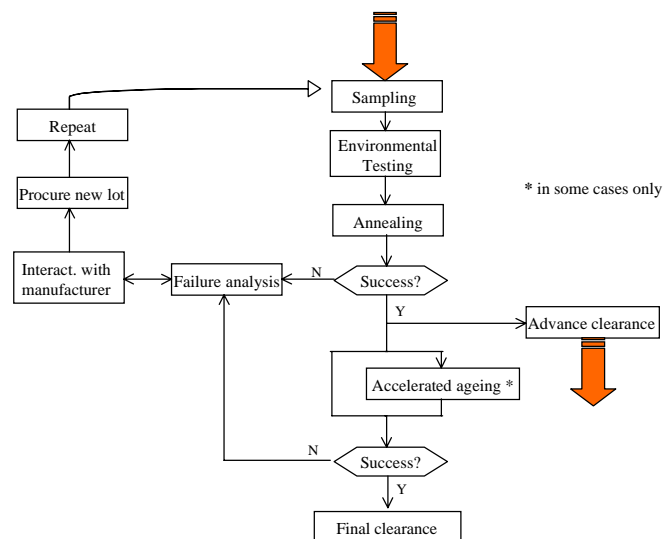

Figure 5: Flow chart of the advance validation procedure.

One or more AVT's per component type will take place during the pre-production and extending into the final production period where necessary. Final device assembly will proceed only after samples from laser and photodiode wafers and naked fibre lots have passed the AVT.

A close working relationship is clearly necessary with the various suppliers of these components, to ensure that the AVT steps are achievable. The precise AVT procedures, actions, and schedule will be agreed in the final contracts.

D. Lot validation

Once pre-production components and assemblies have been fully qualified, production can be launched. Lot validation involves sample testing of every delivered batch, as in Fig. 6, with the outcome of either accepting or rejecting the tested lot.

Results of lot validation tests will be archived in the EDMS database, with a summary sent to the manufacturer. The lot validation step does not include environmental testing and the description here is only given to complete the brief outline of the overall QA procedures. All the environmental QA tests will be covered in the AVT and pre-production qualification steps.

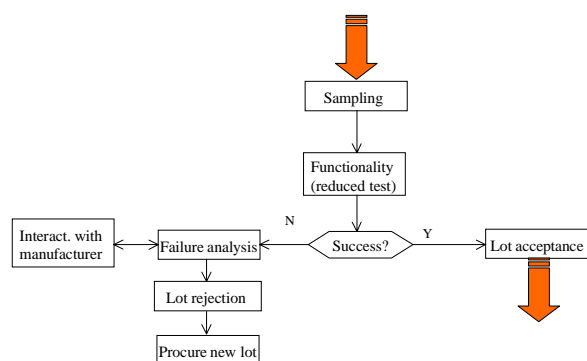

Figure 6: Flow chart of the lot validation procedure.

III. ENVIRONMENTAL QA TEST PLANS

The procedures described in this section focus mainly on radiation damage testing, since this is the most important aspect of the environment affecting the optical links. The Tracker will also operate at a temperature close to -10°C and in a 4T magnetic field. The atmosphere will be constantly flushed, dry nitrogen. Concerning these the thermal aspect of the Tracker environment, all the link components are already specified for operation above -20°C . In addition, components with magnetic packaging have been excluded and recent tests have confirmed that the link performance is not affected by a magnetic field of 4T[6].

A. Radiation damage effects

A brief summary of the radiation damage effects observed in tests carried out on all link components, during the development phase of the project, are listed in Table 1.

Table 1: Summary of the effects of radiation damage in the optical link components to be used in the CMS Tracker.

Component	Radiation damage effects
Laser	Threshold current increase and efficiency decrease. Significant annealing of both effects. No effect on wearout rate.
Photodiode	Leakage current increase and responsivity loss. Some annealing of leakage current but no significant annealing of responsivity loss. No effect on wearout rate. Sensitive to SEU.
Optical fibre	Increased attenuation. Significant annealing of damage. No mechanical degradation.
96-way Optical cable	Attenuation in the optical fibre. No mechanical degradation.
Optical connector	No degradation.
Laser driver chip	No degradation.
Digital receiver chip	No degradation.

B. Lab simulation of the radiation environment

In order to validate components for radiation hardness within the production schedule we are forced to carry out accelerated tests. For radiation effects testing this means using only a limited number of radiation sources, and irradiating the samples with fluxes or dose rates in excess of those expected in the Tracker.

For each type of radiation damage mechanism, namely ionisation, displacement, or single event effect (SEE), we therefore assume that the radiation damage effects from different incident particles (or from particles of different energy) can be compared at some basic level. Under this assumption all validation for a given component, in terms of testing each damage mechanism, can then be made with just one type of radiation source per mechanism. We therefore propose to use photon sources (^{60}Co , or X-ray) for ionisation damage tests, neutron sources for displacement damage tests and proton sources for SEE tests. Suitable radiation sources are identified in the QA manual[1].

The accelerated testing extends to measurements of annealing and wearout degradation. These effects are usually thermally activated and can be accelerated by increasing the temperature. In all of the validation tests the effects expected over the lifetime of the components within the Tracker are then determined by extrapolation of the results from the accelerated tests to the conditions expected at a given location in the tracker.

C. Device-specific tests

A summary of the device-specific environmental QA tests is given in Table 2. The most unusual aspect of the testing programme, which are the advance validation tests, is detailed in the following section with procedures for laser, photodiode and optical fibre AVT.

The reader is referred to the QA manual[1] for full details of the other environmental tests (and functionality) tests that are foreseen.

Table 2: Summary of environmental tests to be performed on optical link components.
Tests in Italics involve other groups and are still to be finalised.

Optical link element	Link system	Pre-production qualification	Advance validation
Laser diode chip	Analogue and Digital	-	total dose, fluence and annealing accelerated ageing
Laser transmitter	Analogue and Digital	magnetic field	-
Laser driver	Analogue and Digital	<i>total dose and annealing accelerated ageing SEE</i>	-
Optohybrid substrate	Analogue and Digital	<i>to be decided</i>	<i>to be decided</i>
Analogue optohybrid	Analogue	<i>total dose, fluence and annealing SEE magnetic field accelerated ageing</i>	-
PIN photodiode receiver	Digital	magnetic field	total dose, fluence and annealing accelerated ageing
Digital receiver amplifier	Digital	<i>total dose and annealing accelerated ageing SEE</i>	-
Digital optohybrid	Digital	<i>total dose, fluence and annealing SEE magnetic field accelerated ageing</i>	-
Optical fibre	Analogue and Digital	-	total dose and annealing
Buffered fibre	Analogue and Digital	total dose	-
Optical fibre ribbon	Analogue and Digital	total dose	-
Ruggedized ribbon	Analogue and Digital	total dose	-
Dense multi-ribbon cable	Analogue and Digital	total dose	-
Optical connectors	Analogue and Digital	total dose magnetic field	-

(i) Laser AVT.

At least 20 devices will be irradiated from each candidate wafer, then aged along with 10 unirradiated devices in advance of the final production of packaged devices from the given wafer. All the samples should be packaged in the final form, to facilitate mounting and testing, and will have already been burned-in prior to delivery.

The lasers will be irradiated under bias, with gamma rays and then neutrons, up to the worst-case equivalent doses and fluences. Both gamma and neutron irradiations will be made at room temperature with in-situ monitoring of the laser L-I and V-I characteristics at periodic intervals before, during and after irradiation. The rates of degradation and annealing of the threshold current and output efficiency can therefore be determined and the results of the damage and annealing tests can then be extrapolated to the conditions of damage and annealing expected in the Tracker.

In the accelerated ageing step the devices will be operated at 80°C for at least 1000 hours to measure any potential wearout degradation. The inclusion of both irradiated and unirradiated samples allows a control of any possible degradation mechanisms that are due to radiation damage. Measurements of the laser L-I and V-I characteristics will be made at periodic intervals during the ageing test. In between measurement cycles, the lasers will be biased at 60mA. This represents the maximum current available with the final laser driver.

Any failure will be analysed post-mortem, in order to establish the cause of failure. Only failures that are intrinsic to the device-under-test will be counted in the statistics of the test. For example, any failure of wire-bonds from the laser to the test-board will not be counted.

Proposed acceptance criteria for pre-production qualification and advance validation are such that 90% of the lasers should remain within all the operating specifications for the system, under the worst-cases of radiation damage exposure, and any additional wearout degradation, when extrapolating to the full 10year lifetime of the links.

(ii) Photodiode AVT.

20 devices will be irradiated from a given wafer, and then aged along with 10 unirradiated devices. The devices should be packaged in the final form and have been burned-in before delivery.

The photodiodes will be irradiated under bias, with gamma rays and then neutrons, up to the worst-case equivalent doses and fluences. Both the gamma and neutron irradiations will be made at room temperature with in-situ monitoring of the photodiode leakage and response characteristics made at periodic intervals before, during and after irradiation. The rates of degradation and annealing can therefore be determined.

The devices will be aged at 80 °C for at least 1000 hours to determine the rate of long-term wearout degradation. In-situ monitoring will be used to make measurements of the photodiode leakage and response characteristics at periodic intervals during the ageing test. The photodiodes will be biased constantly at -2.5V.

A similar type of failure analysis, acceptance criteria and rejection action will apply for the photodiodes as for the laser diodes.

(iii) Optical fibre AVT.

Bare optical fibre samples from each preform will be tested by advance validation to ensure that it is suitable for use in the CMS Tracker, before it is integrated into the final production. The same type of bare fibre is used in all parts of the links: the buffered fibre for pigtails and ribbonized fibre for the ruggedized 12-way cables and the 96-way cables.

Two 100m long samples of optical fibre per preform will be irradiated with gamma rays and neutrons up to the maximum dose and fluence expected inside the Tracker. In-situ measurements of the radiation-induced attenuation in the fibre and the subsequent annealing will be performed in these tests. The proposed acceptance criterion for the preforms tested in the advance validation is that the loss will be no more than 50dB/km. This would be equivalent to a loss of 0.5dB over ~10m of fibre per link channel situated inside the Tracker.

IV. CONCLUSION

All of the components in the CMS Tracker optical links are either commercial off-the-shelf (COTS) components, or devices based on COTS. It is therefore necessary to extend environmental validation tests from the development phase all the way into the production phase of the project.

This document reviewed some of the various test procedures related specifically to compliance of the various test components with the CMS Tracker environment, particularly the intense radiation field.

Advance validation test (AVT) procedures have been introduced as a special measure within the QA programme. These procedures should allow the problems associated with the possible rejection of fully assembled batches of non-compliance of COTS components to be avoided.

V. ACKNOWLEDGEMENTS

The success of the QA programme depends upon a good working relationship between the optical link development team and the various suppliers. We gratefully acknowledge all the suppliers and their valuable contributions to this work.

VI. REFERENCES

- [1] CMS Tracker Optical Links Quality Assurance Manual. K. Gill, J. Troska and F. Vasey (2001).
- [2] CMS Tracker Technical Design Report. CERN LHCC 98-6 (1998).
- [3] A full list of publications of radiation damage tests carried out within the framework of the CMS Tracker Optical Links Project (1996-2001), is available at: http://cms-tk-opto.web.cern.ch/cms-tk-opto/rad_pubs.html
- [4] G. Cervelli et al., "A linear laser driver array for optical transmission in the LHC experiments", Proceedings of IEEE/NSS conference, Lyon (2000).
- [5] F. Faccio et al., "Status of the 80Mbit/s Receiver for the CMS digital optical link", 6th LEB Workshop Proceedings, 299 (2000).
- [6] T. Bauer et al., CMS Note in preparation.

