

**ORGANISATION EUROPEENNE POUR LA RECHERCHE NUCLEAIRE  
EUROPEAN ORGANIZATION FOR NUCLEAR RESEARCH**

Laboratoire Européen pour la Physique des Particules  
European Laboratory for Particle Physics

# **CMS Tracker Optical Control Link Specification**

## **Part 2: Front-end Digital Optohybrid**

**Version 2.1, 22 July, 2003.**

**CERN EP/CME**

<b>1. INTRODUCTION .....</b>	<b>2</b>
1.1. GENERAL SYSTEM DESCRIPTION .....	2
1.2. DOCUMENT STRUCTURE AND CONVENTION .....	3
1.3. RELATED WWW SITES .....	4
1.4. DOCUMENT HISTORY .....	4
1.5. CONTACTS .....	4
<b>2. TECHNICAL REQUIREMENT: FRONT-END DIGITAL OPTOHYBRID .....</b>	<b>5</b>
2.1. DESCRIPTION .....	5
2.2. BLOCK DIAGRAM .....	5
2.3. TARGET OPERATIONAL SPECIFICATIONS (@25°C UNLESS OTHERWISE NOTED).....	6
2.4. IMPLEMENTATION .....	9
2.5. MANUFACTURING SPECIFICATIONS .....	15
2.6. QUALITY ASSURANCE .....	18
2.7. SPECIFICATION TEST TABLE .....	19
<b>3. GLOSSARY .....</b>	<b>23</b>
3.1. SKEW .....	23
3.2. JITTER .....	23
<b>4. REFERENCES .....</b>	<b>24</b>

# 1. Introduction

## 1.1. General system description

This specification defines the design requirements for the digital optical link to be used in the control system of the various sub-detectors of the CMS detector [1.1] at the CERN [1.2] Large Hadron Collider (LHC). The system architecture is based on the token ring concept, with mixed optical and copper sections [1.3]. The system was originally developed for the Tracker subdetector [1.4], where the total number of redundant control rings is 320, corresponding to 2560 optical link fibre channels. Including the other subsystems: ECAL, preshower and pixels, the combined total number of digital control link fibre channels is expected to be 6808.

The CMS optical control link is embedded into the control ring, as shown in Fig 1.1 taking the Tracker system as an example. The optical link is highlighted on the left of the figure, starting and ending at the backend transceiver module which is mounted on the Front End Controller board (FEC). Specifications for the FEC, and communication control unit (CCU) ASICs can be found in [1.5] and [1.6] respectively.

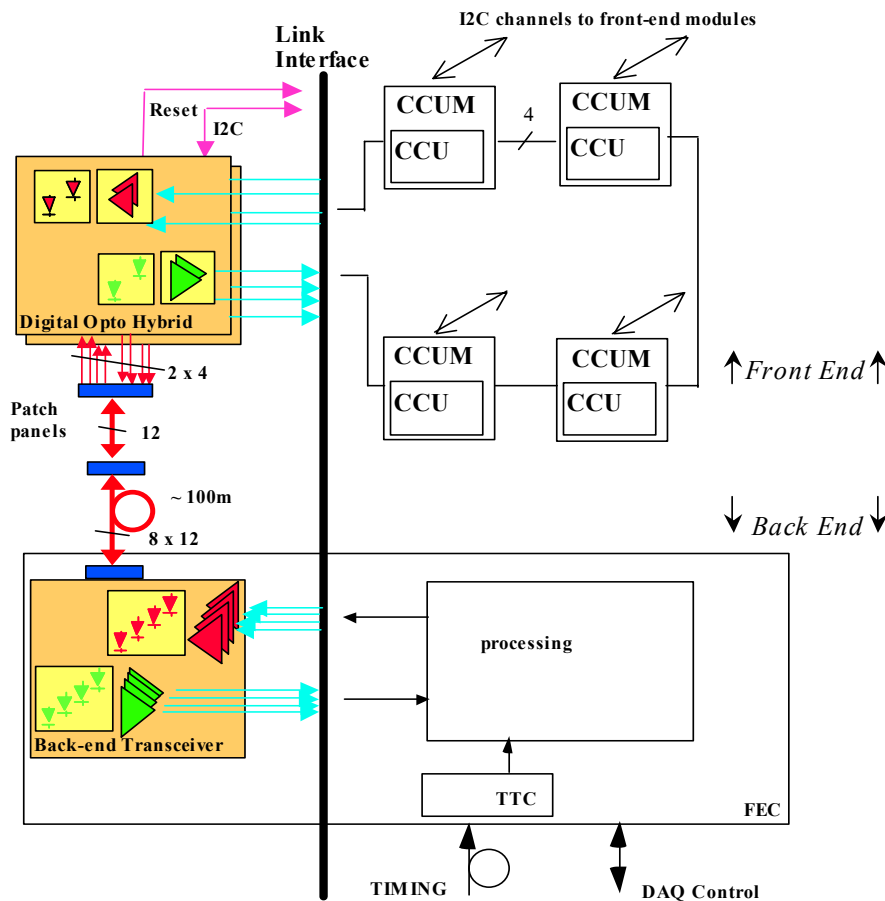

Fig. 1.1. Tracker control ring with optical link highlighted on the left.

The communication architecture proposed to control the embedded electronics is based on two layers. A more detailed description can be found for instance in [1.3]. The first layer (called the Ring) links the FEC and CCU modules (CCUMs) as well as connecting between CCUMs on the same ring. The protocol on this first layer is message-based and is implemented in a way similar to LAN networks. Four lines are required to transmit data (40Mb/s) and system clock (40MHz) with redundancy. Optical links are used to transmit data between the back-end (FEC) and the front-end digital optohybrid (DOH). The data is then communicated between CCUMs via electrical interconnections. The second layer of communication, between the CCUMs and the front-end chips, is entirely electrical and is based on the I<sup>2</sup>C standard protocol.

## 1.2. Document structure and convention

The optical link specification is broken down into eight independent parts, each describing and specifying a different level or function in the system:

- Part 1. System
- Part 2. Digital Opto-Hybrid
  - 2.1 Laser Driver ASIC
  - 2.2 Laser Transmitter
    - 2.2.1 Terminated Pigtail
      - 2.2.1.1 Buffered Fibre
  - 2.3 PIN Photodiode
  - 2.4 Digital Receiver ASIC
  - 2.5 Digital Optohybrid Substrate
- Part 3. Terminated Fibre Ribbon
  - 3.1 Ruggedized Ribbon Harness
    - 3.1.1 Ruggedized Ribbon
- Part 4. Terminated Multi-Ribbon Cable
  - 4.1 Dense Multi-Ribbon Cable
- Part 5. Back-End Opto-Transceiver Module
- Part 6. Distributed Patch Panel
  - 6.1 MU-sMU Adaptor
- Part 7. In Line Patch Panel
  - 7.1 MFS Adaptor
- Part 8. Backend Patch Panel

This particular specification has the following structure:

- |                         |                                   |             |               |
|-------------------------|-----------------------------------|-------------|---------------|
| 1. Introduction         | 2. Technical requirement          | 3. Glossary | 4. References |
| 1.1. System description | 2.1. Description                  |             |               |
| 1.2. Document structure | 2.2. Block diagram                |             |               |
| 1.3. Related WWW sites  | 2.3. Specification                |             |               |
| 1.4. Contact            | 2.4. Implementation               |             |               |
| 1.5. Document history   | 2.5. Manufacturing Specifications |             |               |
|                         | 2.6. Quality Assurance            |             |               |
|                         | 2.7. Specification Test Table     |             |               |

**Parameters still to be determined within the specification are labelled TBD.**

### 1.3. Related WWW sites

- CERN laboratory: <http://www.cern.ch/Public/>
- CMS project: <http://cmsinfo.cern.ch/Welcome.html>
- CMS Tracker Technical Design Report: <http://cmsdoc.cern.ch/ftp/TDR/TRACKER/tracker.html>
- CMS Tracker Electronic System: <http://cmstrackercontrol.web.cern.ch/CMSTrackerControl/docmain.htm>
- CMS Tracker Optical Links: <http://cms-tk-opto.web.cern.ch/>
- FED developments: [http://www.te.rl.ac.uk/esdg/cms\\_fed\\_pmc/index.html](http://www.te.rl.ac.uk/esdg/cms_fed_pmc/index.html)
- APV and MUX developments: <http://www.te.rl.ac.uk/med/>

### 1.4. Document history

Rev. 1.0, 13/11/02 (KG)	Draft
Rev. 1.1, 17/12/02 (KG)	Decreased nominal laser efficiency to 16 $\mu$ W/mA.
Rev. 1.2, 21/1/03 (KG)	Number of pigtail lengths to 3. LVDS min spec. Text labels for active components updated, but drawings still to be changed. DOH area and thickness to be finalised and updated.
Rev. 1.3, 7/3/03 (KG)	DOH v4 (preliminary) design figures added.
Rev. 1.4, 9/5/03 (KG)	Manufacturing specs added. QA section added. Number of control rings increased for new ECAL quantity.
Rev. 1.5, 30/6/03 (KG)	Manufacturing specs modified to include industrial standards.
Rev. 2.0, 8/7/03 (KG)	Photographs and schematics of v4 prototype included CERN specs from Design Office included
Rev. 2.1, 22/7/03 (KG)	Minor corrections. Burn-in added.

### 1.5. Contacts

All questions regarding this document should be addressed to:

F. Vasey  
EP Division  
CERN  
CH-1211 Geneva 23

Fax: +41 22 767 2800  
Phone +41 22 767 3885  
E-mail [francois.vasey@cern.ch](mailto:francois.vasey@cern.ch)

K. Gill  
EP Division  
CERN  
CH-1211 Geneva 23

Fax: +41 22 767 2800  
Phone +41 22 767 8583  
E-mail [karl.gill@cern.ch](mailto:karl.gill@cern.ch)

## 2. Technical requirement: front-end digital optohybrid

### 2.1. Description

The digital optohybrid (DOH) is a compact radiation resistant transceiver assembly with two lasers and a laser driver ASIC (LLD[1.7]), and two photodiodes and a receiver ASIC (RX40[1.8]), all mounted on a 4-layer FR4 hybrid. The electrical interface is a 26pin NAI S connector. The optical interface consists of 4 single-mode fibre pigtailed with individual MU connectors.

The two receiver channels on the DOH transmit the LHC 40MHz clock (CK) (as well as L1 trigger and resynchronisation signals) and control data (DA) at 40Mbit/s in the direction from the FEC to the ring of CCUMs. The two transmitter channels send clock and data to the FEC from the ring of CCUMs.

The hard-reset for the front-end ASICs is also generated by the RX40 on the DOH, following reception of a reset request (a signal of at least 10 consecutive '0' levels on the DA line) sent by the FEC over the DA optical link channel.

640 DOH will be required for the Tracker, 112 for the Pixels, 846 for ECAL and 104 for the Preshower (not including yield or spares), a total of 1702 hybrids. At least 1800 DOH will be manufactured.

There will be two versions of the optohybrid: DOH 056 and DOH 200. The first version has 56cm fibre pigtail and the second has 200cm long fibre pigtailed. Of the 1800 hybrids produced, 1570 will be DOH 056 and 230 will be DOH 200.

### 2.2. Block diagram

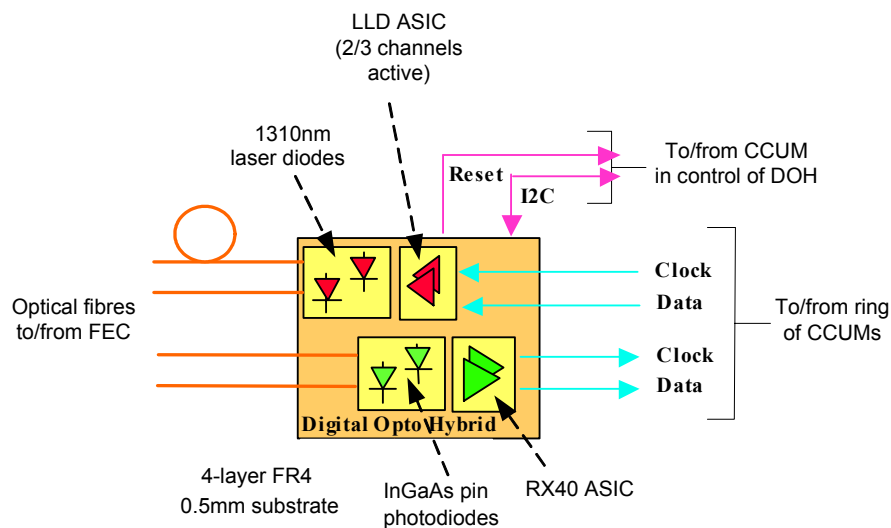

Fig. 2.1. Front-end digital optohybrid block diagram

### 2.3. Operational Specifications (@25°C unless otherwise noted)

#	Operational specifications	min	typ	max	unit	note
2.1	Bit Rate	2		100	Mb/s	Balanced code
2.2	Bit error rate			$10^{-12}$		
2.3	Skew			1	ns	Between the 2 fibres coming from the same hybrid, see glossary 3.1
2.4	Jitter			0.25	ns	Rms, see glossary 3.2
2.5	Operation rate		4000		hrs/year	Over lifetime of 10 years.
	Specs 2.6 to 2.10					Reserved for future use

#	Physical specifications	min	typ	max	unit	note
2.11	Number of Tx channels	2				LD0 on Fig. 2.3 = Clock LD1 on Fig. 2.3 = Data
2.12	Number of Rx channels	2				PD0 on Fig. 2.3 = Clock PD1 on Fig. 2.3 = Data
2.13	Size	21.5x35x4.5			mm	See Fig 2.3, Fig. 2.4.
	Specs 2.14 to 2.20					Reserved for future use

#	Electrical specifications	min	typ	max	unit	note
2.21	Differential input voltage	±300			mV	Into 120Ω. Note that the LLD ASIC has an analogue transfer characteristic.
2.22	Input impedance		120		Ω	R1, R2, R3 and R4 = 56Ω (TBD)
2.23	Differential output voltage	±250	±400		mV	LVDS. Should be terminated differentially with 100Ω.
2.24	Reset Output	Active low				Generated by RX40 upon reception of 10 consecutive '0' levels on DA channel (PD1 on Fig 2.3).
2.25	Power supply	2.25		2.7	V	
2.26	Power dissipation		350		mW	Tx contributes 220mW [1.7] Rx contributes 125mW [1.8]
2.27	I2C address	11100				Fixed
2.28	Default LLD laser I2C bias setting	X <sub>1</sub> X <sub>2</sub> X <sub>3</sub> 0000				Where X <sub>1</sub> X <sub>2</sub> X <sub>3</sub> = 011 = 48 <sub>decimal</sub> (TBD). Approximately 22mA. Value is selected during production.
2.29	Default LLD gain setting	12.5			mS	Hard-wired in LLD
2.30	Electrical connector	26-way male NAIS				See fig. 2.5 for connector pin assignment
	Specs 2.31 to 2.40					Reserved for future use

#	Optical specifications	min	typ	max	unit	note
2.41	Wavelength	1260	1310	1360	nm	
2.42	Tx average output power at power up	-8		-4	dBm	Assumes laser efficiency of $16\mu\text{W}/\text{mA}$ ( $\pm 20\%$ ), I2C default =48, $I_{\text{bias}} = 0.45\text{mA} * \text{I2C step}$ ( $\pm 20\%$ ) and $I_{\text{threshold}} = 5\text{mA}$ .
2.43	Tx optical modulation amplitude	-11		-5	dBm	Assumes voltage input of 800mV ( $\pm 20\%$ ), Gain = 12.5mS ( $\pm 20\%$ ) and laser efficiency of $16\mu\text{W}/\text{mA}$ ( $\pm 20\%$ ). DOH biased such that amplitude not truncated by laser threshold.
2.44	Rx sensitivity			-18	dBm	
2.45	Rx saturation (d.c.)	-3			dBm	Maximum average input power.
2.46	Rx saturation (a.c.)	-3			dBm	Maximum optical modulation Amplitude into Rx.
2.47	Optical fibre type	single mode tight-buffered 9/125/250/900 $\mu\text{m}$				
2.48	Pigtail length	0.56		0.58	m	Short pigtail length laser
		0.56		0.60		Short pigtail length photodiode
		2.00		2.04		Long pigtail length laser and photodiode
2.49	Optical connector	MU				
2.50	Tensile strain	7.0			N	
	Specs 2.51 to 2.60					Reserved for future use

#	environmental specifications	min	typ	max	unit	note
2.61	Magnetic field resistance	4			T	Parallel to particle beam axis
2.62	Hadronic fluence <sup>1</sup>			3e14	1/cm <sup>2</sup>	Integrated over lifetime <sup>2</sup> , 90% charged particles, 10% neutrons, see ref [2.1]
2.63	Gamma dose			1.5e5	Gy(Si)	Integrated over lifetime <sup>2</sup> , see ref [2.1]
2.64	Temperature	-20		50	°C	Operation and storage
2.65	Operating humidity	Dry lab environment during testing				Dry nitrogen flow during operation in Tracker.
	Specs 2.66 to 2.80					Reserved for future use

<sup>1</sup> Qualification of the parts for radiation resistance is the sole responsibility of CERN. No radiation testing is required of the optohybrid manufacturer.

<sup>2</sup> Foreseen operating lifetime: nominal 10 years.



#	safety specifications		note
2.81	Optical	laser system hazard level 1	IEC 825-1, 825-2, See reference [2.2]
2.82	Fire	CERN standards for underground equipment	CERN IS23 and IS41, see reference [2.3].
	Specs 2.83 to 2.99		Reserved for future use

## 2.4. Implementation

Fig. 2.2: Photograph

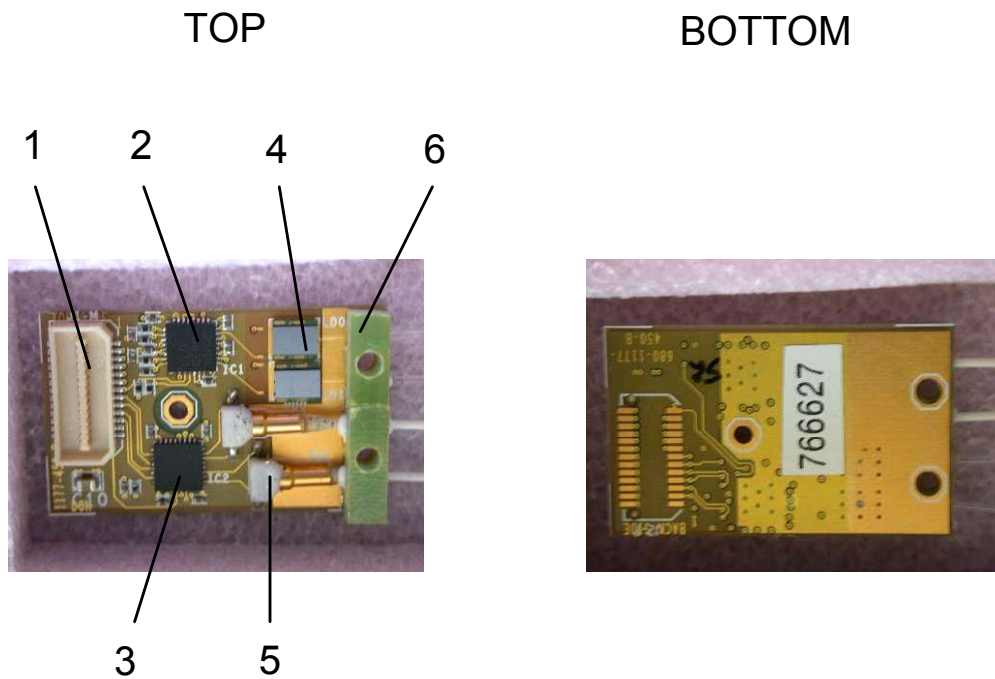

1. NAI5 26-way Header connector. 2. LLD ASIC. 3. RX40 ASIC. 4. Lasers (ST Microelectronics, Fig. 2.6). 5. Photodiodes (Fermionics, Fig. 2.7). 6. Fibre clamp. 7. QR code label not shown. 8. Laser protective cover not shown. The large label on the bottom side is not foreseen on the final DOH. Parts 2, 3, 4, 5 and 7 will be supplied by CERN.

Fig. 2.3: Mechanical drawing.

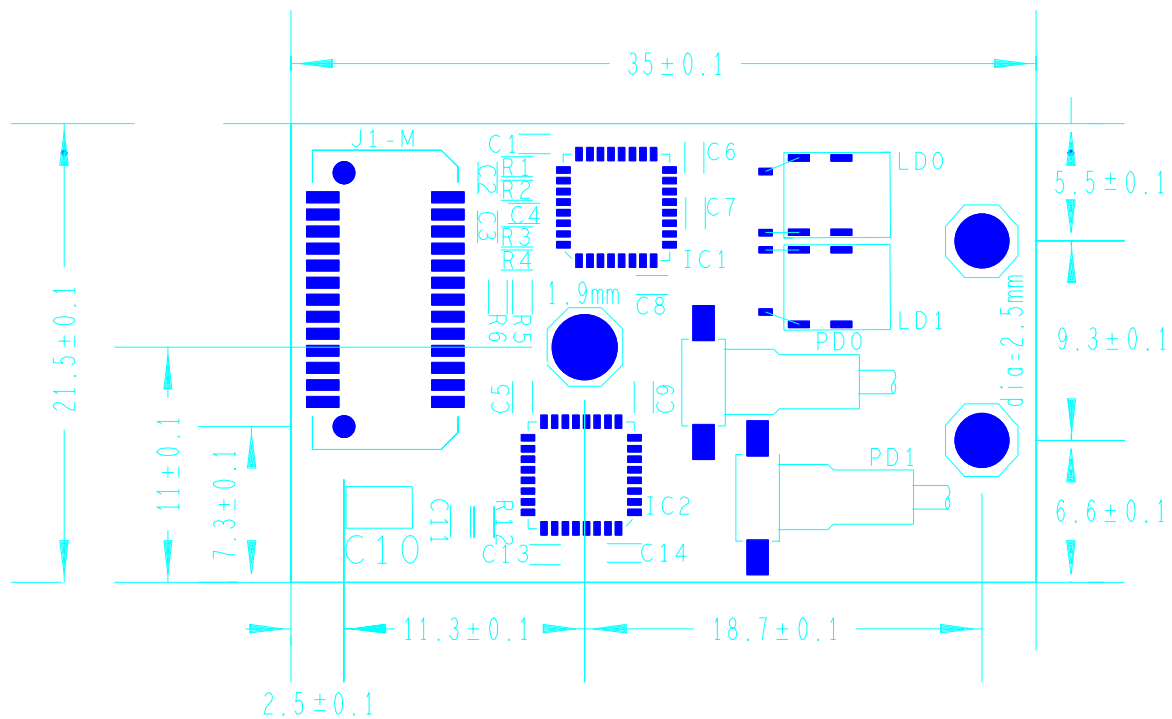



### 2.4.1. Component list

Sub-component	Part Number on DOH	Part Type	Supplier <sup>1</sup>	Value	Tolerance	Package	Voltage or Power rating	Quantity	Provided by CERN
Optohybrid substrate			Manufacturer					1	No
Header connector	J1-M	AXN426430S	NaiS Matsushita			26-pin Header (male) (0.8mm) Height=4mm		1	No
Laser Driver ASIC [see Reference 1.7]	IC1	LLD2	CERN			LPCC 32		1	Yes
Receiver ASIC [see Reference 1.8]	IC2	RX40_V1_2 <sup>2</sup>	CERN			LPCC 32		1	Yes
Laser diode	LD0, LD1		ST Microelectronics			Custom (see Fig. 2.5)		2	Yes
Photodiode	PD0, PD1		Fermionics			Custom (see Fig. 2.6)		2	Yes
SMD Resistor	R1, R2, R3, R4	Any	Any	56 ohms	5%	R0402	1/16 W	4	No
SMD Resistor	R5, R6	Any	Any	2k2 ohms	5%	R0402	1/16 W	2	No
SMD Resistor	R12	Any	Any	10k ohms	5%	R0402	1/16 W	1	No
SMD Ceramic Capacitor	C1, C4, C5, C6, C7, C8, C9, C11, C13, C14	X5R	Kemet	100nF	10%	C0402	10V	10	No
SMD Ceramic Capacitor	C2, C3	X7R	Kemet	1nF	10%	C0402	10V	2	No
SMD Ceramic Capacitor	C10	X7R	Kemet	1uF	10%	C0805	10V	1	No
QR Code Label	Not shown.		NTT			5.5x5.5x0.5mm <sub>3</sub> (see Fig. 2.7)		1	Yes
Fibre Clamp			Manufacturer					1	No

<sup>1</sup> The components where the supplier has been specified have been qualified as radiation resistant by CERN.

<sup>2</sup> For DOH intended for Pixel detector system in CMS, a different version of the receiver RX40 may be used. In this case the pixel DOH may be grouped into one production lot.

Laser cover			Manufacturer					1	No
-------------	--	--	--------------	--	--	--	--	---	----

Fig. 2.5: Electrical schematic of DOH

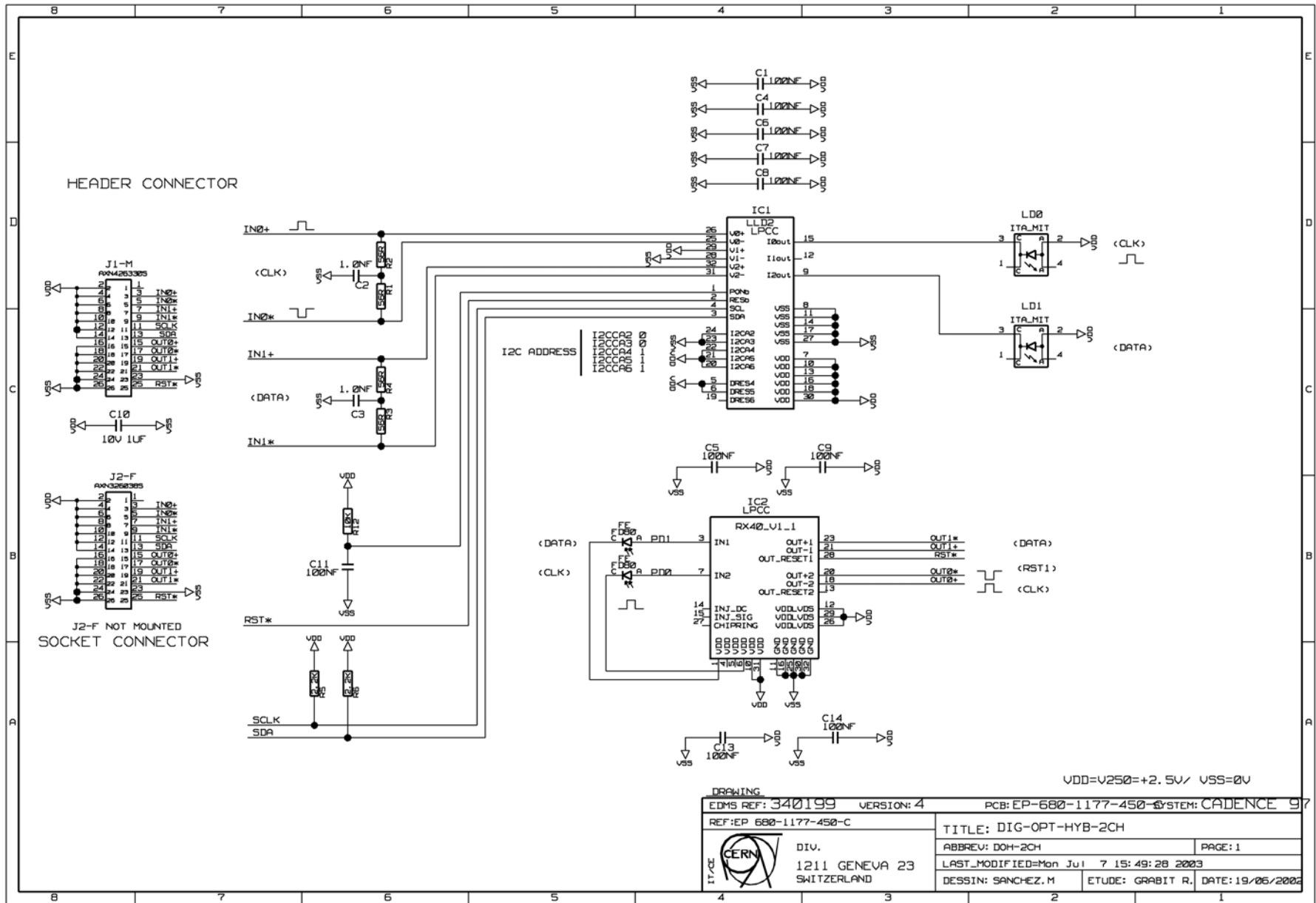

Figure 2.6: Laser assembly and MU-connector.

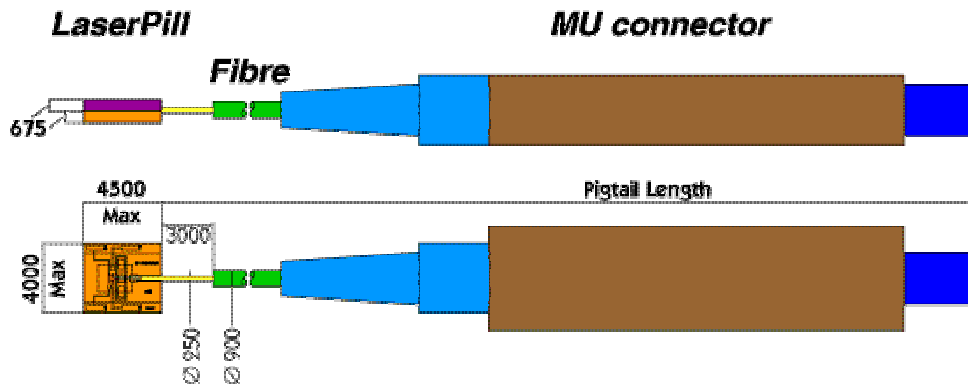
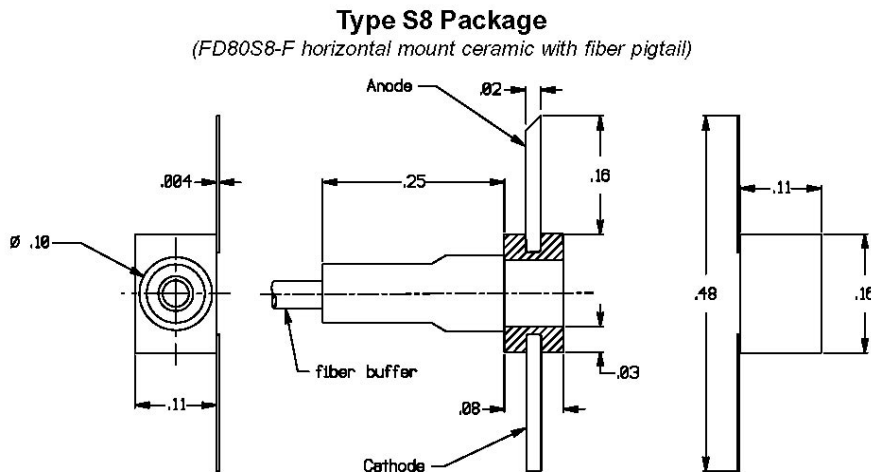

Figure 2.7: Photodiode assembly. Supplied with MU-connector identical to laser in Fig. 2.6.



(All dimensions in inches)

Figure 2.8: QR code label. Actual size 5x5x0.5 mm<sup>3</sup>.



## 2.5. Manufacturing Specifications

### 2.5.1. Substrate

#	Specification	min	typ	max	unit	note
2.101	Substrate Manufacture Quality Standard	IPC A 600 Class 3 and Norme Francaise NF C 93-713 Classe 6 <sup>1</sup>				Statement of compliance required from Manufacturer.
2.102	Material	FR4				
2.103	Number of layers	4				
2.104	Total final PCB thickness		500	600	μm	
2.105	Thickness of FR4	Top layer = 100			μm	for impedance control (see Fig. 2.4)
		Bottom = 100				
2.106	Copper track thickness		17 (+8 plating)		μm	Top, bottom layers 17microns copper plus 8 microns plating. Impedance controlled.
			35		μm	Inner layers
2.107	Copper track width on signal lines		150		μm	Impedance controlled.
2.108	Copper track separation on signal lines		180		μm	Impedance controlled.
2.109	Via diameter	200			μm	Plated area around via has 200μm larger diameter. <sup>2</sup> (NF Classe 6)
2.110	Bond pad material	<i>Cu-Ni-Au</i>				
	Specs 2.111 to 2.130					Reserved for future use

<sup>1</sup> Norme Francaise NF C 93-713 (1989) used by the CERN design office. See Ref [2.4].

<sup>2</sup> This feature of the DOH design is Class 6 in Norme Francaise NF C 93-713.



2.5.2. *Passive sub-components*

#	Specification	min	typ	max	unit	note
2.131	Assembly Quality Standard	IPC A 610 Class 3				Statement of compliance required from Manufacturer.
2.132	Resistor type	R0402				R1 to R6, and R12.
2.133	Resistor values	See Section 2.4.1				
2.134	Resistor tolerances			5	%	
2.135	Capacitor types	C0402 X5R				C1, C4 to C9, C11, C13 and C14.
		C0402 X7R				C2, C3
		C0805 X7R				C10
2.136	Capacitor values	See Section 2.4.1				
2.137	Capacitor tolerances			10	%	
2.138	Connector type	NAiS Matsushita 26 pin Header				Part number: AXN426430S 26-pin male (0.8mm). Height = 4mm.
2.139	Fibre clamp material	FR4 or Glue only (TBD)				e.g. FR4 piece-parts glued as for CERN prototypes. Alternatively no FR4 and only glue (e.g. Epotek 310) to fix fibre on the DOH board.
2.140	Fibre clamp glue	Non-conducting epoxy				Type TBD. Curing no more than 3 hrs at 60°C. No excess glue on lasers or naked fibre parts.
2.141	Fibre clamp dimensions	Width TBD Length = 21.5 Height = 4.0			mm	Applies only if FR4 piece parts used (see spec 2.139). Length matches DOH width. Height matches mated NAiS connector.
2.142	Fibre clamp positional tolerance			0.5	mm	
2.143	Laser protection cover material	FR4 or Ceramic				TBD
2.144	Laser protection cover dimensions			TBD	mm	Check by visual inspection. Total height of hybrid should be 4.5mm.
2.145	Laser protection cover positional tolerance			0.5	mm	
2.146	Laser protection cover glue	Non-conducting epoxy				Curing no more than 3 hrs at 60°C. No excess glue on lasers or naked fibre parts.
2.147	Label	QR code 5 x 5 x 0.5			mm	See Fig. 2.8. Positioning TBD. There should be no other labels attached to the DOH.
2.148	Label glue type	TBD				Curing no more than 3 hrs at 60°C.
	Specs 2.149 to 2.160					Reserved for future use

### 2.5.3. Active subcomponents

#	Specification	min	typ	max	unit	note
2.161	Assembly Quality Standard		IPC A 610 C Class 3			Statement of compliance required.
2.162	Laser driver ASIC package		LPCC 32 pin			Ref [1.7]. CERN supplied known good die.
2.163	Receiver ASIC package		LPCC 32 pin			Ref [1.8]. CERN supplied known good die.
2.164	Laser package		Custom			See Fig. 2.6 CERN supplied known good die. Same fibre length as for photodiode on same DOH.
2.165	Laser package handling		Very fragile			Tensile force on fibre <3N. No torsion to be applied to fibre. Not pick-and-place compatible. All fibres to be unwound and relaxed during assembly.
2.166	Laser package glue		Thermally conductive, electrically insulating epoxy. Type TBD.			No excess glue on or around laser. Curing no more than 3 hrs at 60°C.
2.167	Laser package bonding		Double bond 25um Al Si 1% Or Au 25-31um MIL-STD-883E			For redundant reliability. Minimize height of bond. Bond-strength specification must satisfy MIL-STD-883E, Method 2011.7 Wire-pull, Condition D.
2.168	Photodiode package		Custom			See Fig. 2.7 CERN supplied known good die. Same fibre length as for laser on same DOH.
2.169	Photodiode package handling		Fragile			Tensile force on fibre <3N. No torsion to be applied to fibre. Not pick-and-place compatible. All fibres to be unwound and relaxed during assembly
2.170	Photodiode package glue		Non-conductive epoxy			Curing no more than 3 hrs at 60°C.
2.171	Photodiode package soldering		TBD			e.g. Sn60Pb40, Type 5 core ERSIN 362, diameter 0.46mm. Lead-frame to be cut to correct size. Rework limits TBD.
2.172	Hybrid mechanical shock resistance		MIL-STD-883E			Must satisfy Method 2002.3 Condition B.
	Specs 2.173 to 2.199					Reserved for future use

## 2.6. Quality Assurance

### 2.6.1. Standards

Manufacturer to provide details of compliance with relevant standards:

- Substrate manufacture: IPC A 600F Class 3.
- SMD mounting: IPC A 610C Class 3
- Solder mounting (Photodiode): IPC A 610C Class 3
- Bonding. (Laser): MIL STD 883

### 2.6.2. Documentation

Manufacturer to provide process flow details to CERN.

Test data to be provided by manufacturer for every delivered DOH. All test data will be exchanged in electronic form.

### 2.6.3. CERN supplied components

Minimum 100% free-issued supply of lasers, photodiodes, RX40 ASICs, LLD ASICs, QR codes.  
Up to 10% additional quantities of each part will be free-issued to cover <100% yield.

### 2.6.4. Testing

The testing is summarized in Section 2.7 and the procedures are detailed in a separate QA document, Ref. [2.5].

Visual inspections to be performed according to IPC standards.

Electrical tests to be performed during DOH assembly using CERN-supplied test equipment (TBD).

Electro-optical tests to be performed after DOH assembly (100%) using CERN-supplied test equipment as in Section 2.7.2.

Reliability, Qualification and Acceptance testing to be performed on pre-production and production lots as in Sections 2.7.2 and 2.7.3.

### 2.6.5. Component Traceability

QR codes (for lasers and photodiodes supplied by CERN already attached) near MU connectors.

QR code (supplied by CERN) to be attached on DOH (See Fig. 2.8).

Manufacturer will be required to use QR codes for associating test data with components.

### 2.6.6. Shipping, storage and handling requirements

Packaging: Delivery package from ST (containing 2 lasers) to be re-used as the DOH package.

ESD: Protection measures to be applied at all times, according to IPC A 610C.

Fibre handling: No excessive strain to be put on fibres, neither pull nor twist.

Always ensure that the fibres are relaxed during mounting and testing of the components.

The fibres should always be handled carefully to avoid scratches and cuts to the acryllate buffer material.

## 2.7. Specification Test Table

### 2.7.1. Manufacturing Tests

#	Specifications to be tested	<i>(Table to be completed by manufacturer)</i>			
		Pre-production series		Production series	
		Intention to Test	Sample quantity (%)	Intention to Test	Sample quantity (%)
2.102	Material				
2.103	Number of layers				
2.104	Total final PCB thickness				
2.105	Thickness of FR4				
2.106	Copper track thickness				
2.107	Copper track width on signal lines				
2.108	Copper track separation on signal lines				
2.133	Resistor values				
2.134	Resistor tolerances				
2.135	Capacitor types				
2.136	Capacitor values				
2.137	Capacitor tolerances				
2.138	Connector type				
2.139	Fibre clamp material				
2.140	Fibre clamp glue				
2.141	Fibre clamp dimensions				
2.142	Fibre clamp positional tolerance				
2.143	Laser protection cover material				
2.144	Laser protection cover dimensions				
2.145	Laser protection cover positional tolerance				
2.146	Laser protection cover glue				
2.147	Label				
2.148	Label glue type				
2.164	Laser package				
2.165	Laser package handling				
2.166	Laser package glue				
2.167	Laser package bonding				
2.168	Photodiode package				
2.169	Photodiode package handling				
2.170	Photodiode package glue				
2.171	Photodiode package soldering				

### **2.7.2. *Assembly tests, pre-production qualification and lot acceptance tests***

CERN will provide a test-system to the manufacturer which will allow the key functional parameters (marked 'C' in the following Table) to be tested rapidly on 100% of assembled DOH boards. A more complete set of tests, characterizing the full functionality of the hybrid, will be made on DOH boards at CERN at 100% level during pre-production and at least 5% level during lot acceptance. All of these tests are detailed in Ref [2.5].

The manufacturer is expected to supply CERN with DOH that pass the assembly test and meet all other criteria detailed in the IPC standards.

Reworking or repair of DOH boards is acceptable so long as the delivered board also meets the required standards and specifications and passes the assembly test.

No failures are allowed in a given pre-production test step, or during acceptance of a delivered lot.

100% of DOHs will be subjected to burn-in, with power-on, at 50°C for 72 hours, before integration into CMS.

In the case of failure of a DOH during pre-production qualification or during lot acceptance the cause of failure will be determined by CERN and/or the manufacturer. If required, a larger quantity of devices could be subjected to tests, or more detailed testing carried out, in order to diagnose the cause of failure.

If a device failure is related to a manufacturing process, the manufacturer is expected to resolve the problem and then supply a new delivery of devices for qualification or lot acceptance. In the case of failure during burn-in that is related to a manufacturing process, the manufacturer is expected to repair or replace the failed device.

If device failure occurs due to reasons not associated to the manufacturing process, then CERN reserves the right to modify the DOH design, the component parts, the specifications, or the test-procedures as necessary.

#	Specifications to be tested	At Manufacturer	At CERN	
		Assembly test (100%)	Pre-production qualification (100%)	Lot acceptance (>5%)
2.1	Bit-rate	C	◆	◆
2.2	Bit-error-rate		◆	TBD
2.3	Skew		◆	
2.4	Jitter		◆	
2.11	Number of Tx channels	C	◆	◆
2.12	Number of Rx channels	C	◆	◆
2.13	Size	◆	◆	◆
2.21	Differential input voltage	C	◆	◆
2.22	Input impedance		◆	◆
2.23	Differential output voltage	C	◆	◆
2.24	Reset output	C	◆	◆
2.25	Power supply		◆	
2.26	Power dissipation		◆	◆
2.27	I2C address	C	◆	◆
2.28	Default LLD laser I2C bias setting	C	◆	◆
2.29	Default LLD gain setting		◆	◆
2.30	Electrical connector	C	◆	◆
2.42	Tx average output power at power-up	C	◆	◆
2.43	Tx optical modulation amplitude		◆	◆
2.44	Rx sensitivity	C	◆	◆
2.45	Rx saturation (d.c.)	C	◆	◆
2.47	Fibre type	◆	◆	◆
2.48	Pigtail length	◆	◆	◆
2.49	Optical connector	◆	◆	◆

**2.7.3. Reliability tests on pre-production devices**

All of the following tests are detailed in Ref [2.5].

All of the tests will be performed by CERN with the exception of the mechanical shock and bond-pull tests, which the manufacturer will perform on pre-production DOH samples. The manufacturer will report the test results to CERN within one month of the test.

All of the tests have to be passed for successful qualification of the pre-production batch.

For the magnetic field and radiation damage tests, the responsibility for the tests and the consequences of the results is taken by CERN.

If there are found to be problems in these tests, CERN reserves the right to modify the DOH design, change the specifications, change component parts, or modify the test-procedures as necessary.

#	Specifications to be tested	Reliability Tests by Manufacturer	Reliability Tests by CERN
2.50	Tensile strength		◆ <sup>1</sup>
2.61	Magnetic field resistance		◆
2.62	Hadronic fluence		◆
2.63	Gamma dose		◆
2.64	Temperature		◆
2.167	Laser package bonding	◆	
2.172	Hybrid resistance to mechanical shock and vibration	◆	

---

<sup>1</sup> Non-destructive tensile tests will also be part of lot acceptance.

### 3. Glossary

#### 3.1. Skew

The skew is determined by measuring, for two channels, the average time  $\overline{t_{50}}$  required for a step response signal to reach 50% of its end value. The skew between channels i and j is defined as:

$$t_{\text{skew}} = \overline{t_{50,j}} - \overline{t_{50,i}}$$

#### 3.2. Jitter

The rms jitter is defined as the rms deviation of the time  $t_{50}$  required for a step response signal to reach 50% of its end value:

$$t_{\text{jitter}} = \sqrt{\overline{(t_{50} - \overline{t_{50}})^2}}$$



## 4. References

- [1.1] <http://cmsinfo.cern.ch/cmsinfo/Welcome.html>
- [1.2] <http://www.cern.ch/>
- [1.3] A. Marchioro, " Specifications for the Control Electronics of the CMS Inner Tracker", Draft V2, CERN
- [1.4] The tracker project, technical design report, CERN/LHCC 98-6, CMS TDR 5
- [1.5] A. Marchioro, "FEC specification", Draft, CERN
- [1.6] A. Marchioro, "CCU specification", Draft, CERN
- [1.7] G. Cervelli et al., "A radiation tolerant laser driver array for optical transmission in the LHC experiments", Proceedings of LEB Workshop, 2001.  
<http://proj-lld.web.cern.ch/proj-lld/>
- [1.8] F. Faccio et al., "Status of the 80Mbit/s Receiver for the CMS digital optical link", Proceedings of LEB Workshop 2000.  
<http://proj-rx40.web.cern.ch/proj-rx40/>
- [2.1] M. Huhtinen, "Studies of neutron moderator configurations around the CMS inner tracker and Ecal", CERN CMS TN/96-057, 1996.
- [2.2] K. Gill, "Laser safety in the CMS Tracker optical links", <http://edms.cern.ch/document/338505/1>.
- [2.3] [http://www.cern.ch/CERN/Divisions/TIS/safdoc/instr\\_en.html](http://www.cern.ch/CERN/Divisions/TIS/safdoc/instr_en.html)
- [2.4] CERN Design Office DOH spec file: 680 1177-450 C
- [2.5] Front-end Digital Optohybrid (DOH) Test Procedures. CMS-TK-QP-0009